

SPATIALLY ADMINISTERING THE MARINE ENVIRONMENT

L. Strain¹, A. Binns², A. Rajabifard³ and I. P. Williamson⁴

¹M.GeomEng Candidate

²Research Fellow

³Deputy Director

⁴Director

Centre for Spatial Data Infrastructure and Land Administration
Department of Geomatics, The University of Melbourne, Victoria 3010, Australia
Email of presenting author: l.strain@pgrad.unimelb.edu.au

KEYWORDS: marine administration, marine cadastre principles, spatial data infrastructure

ABSTRACT

Current coastal zone management initiatives do not go far enough in terms of strategies to combat issues of management of overlapping public, commercial and private rights. Most initiatives are basic information systems which show in detail where an oil platform is located or where the boundary lines for a fishery is located. This is of course important information, but it does not deal with the institutional, administrative and legal arrangements as a whole. Two Australian Research Council (ARC) linkage projects involving the Department of Geomatics (University of Melbourne), six state and National Government agencies (Australia, New Zealand, WA, Vic, NSW & QLD) and GeoFix Pty Ltd have been established to develop a marine cadastre for Australia's maritime jurisdiction. The fundamental objective of these projects is to create a comprehensive spatial data infrastructure whereby rights, restrictions and responsibilities in the marine environment can be effectively assessed, administered and managed.

The advent of the Australian Spatial Data Infrastructure (ASDI) as a tool to help coordinate access to spatial data is of benefit to stakeholders across the country, incorporating the technologies, standards and policies which help link people with data. ANZLIC, Australia's peak spatial information body, has made a commitment to establishing the ASDI across both land and sea, further strengthening the management of the coastal zone. This should facilitate the sharing of marine spatial information through the building of partnerships, which are inherent to the success of an SDI, creating a more holistic approach to the management of rights, restrictions and responsibilities in the coastal zone.

This paper will discuss the issues involved in establishing a spatial information based management system for the marine environment from a cadastral and SDI perspective. It is important to use and learn from the terrestrial cadastre, facilitating a strong link between the land and marine environments, helping to create a seamless management system across the country's coastal zone.

BIOGRAPHY OF PRESENTER

Lisa completed a Bachelor of Geomatics Engineering and a Bachelor of Environmental Science in 2003. During undergraduate study Lisa demonstrated for practical classes in first year engineering and geomatics surveying subjects. She also undertook vacation work for the Civil Contractors Federation, and for Hobsons Bay City Council.

Lisa commenced her Masters in February 2004, under the ARC marine cadastre research grant with cooperation with Land Victoria, Geoscience Australia, Department of Land Administration WA, Department of Lands NSW and Land Information New Zealand.

INTRODUCTION

Australia lays claim to a huge maritime area that must be managed in terms of sustainable development objectives. Historically, this management has occurred through sectoral planning, with fisheries agencies managing fisheries and environmental agencies managing the environment. This gives rise to the need for cooperation between agencies which can be difficult to achieve. Often agencies function in isolation from one another and hence stakeholders such as commercial fisherman may only have clear spatial certainty of what rights other fisherman have within prescribed fisheries. This does not meet users needs adequately as there may also be shipping channels or newly prescribed native title areas within the fishery that they may have no knowledge of. Current coastal zone management initiatives do not go far enough in terms of strategies to combat these issues of management of overlapping public, commercial and private rights.

The establishment of a marine administration system is of significant importance to Governments, government policy makers and marine authorities in Australia. Such a system is needed to support the increasing cultural, economic, environmental and sustainable development demands on coastlines, territorial waters and oceans surrounding Australia.

This paper identifies and analyses fundamental cadastral and land administration principles that may allow the recording of rights, restrictions and responsibilities and aid in the management of overlapping boundaries in Australia's marine environment. There are obvious benefits to utilizing what has been learnt from the development of land based management practices over the past 200 years. This is especially so considering the majority of marine activity occurs at the land/marine interface or coastal zone, particularly from high water mark (HWM) out to a limit of 12 nautical miles. The paper also highlights the development of Spatial Data Infrastructures (SDI) as a means to provide greater access to up-to-date and accurate marine spatial data, including the development of the National Oceans Office (NOO) Marine Portal, and the development of partnerships to aid in management and sharing of marine spatial data and resources.

CADASTRAL AND LAND ADMINISTRATION PRINCIPLES

Policy Principles

According to Williamson [2001], one of the most important aspects of any land administration system is the need for a national or state land policy. "Policy drives legislative reform, which in turn results in institutional reform and finally implementation with all its technical requirements". Within the marine environment, this has become a reality with the NOO developing a National Oceans Policy in 1999, providing a major step forward in providing national policy direction for the administration of the marine environment. The policy recognised the complexity of rights, restrictions and responsibilities relating to the marine environment, setting out a vision to address natural resource management and environmental sustainability objectives. The policy aims to aid in the development and implementation of practices to provide a common organisational structure in the development of marine plans for the sustainable management of Australia's oceans.

Management of Australia's maritime territory however is divided between the states and national government, with the NOO being the national government body for the management of ocean territory. The states are not bound by the policies of the NOO, and hence there are 8 different ocean management regimes in Australia. If we are to avoid some of the complexities of Australia's state based terrestrial cadastral systems evolving in the marine environment, states need to make sure that they align to this national policy in the management of their ocean areas. For example the majority of marine pollution comes from land-based sources and flows into state controlled ocean. In order for the national policy to be effective in minimizing this pollution, states must align to the national policy.

Tenure Principles

The ability to manage land is made more difficult by the range of tenures that exist, each requiring a different land administration response. Diverse forms of tenure also exist in the marine environment. The ability to effectively identify and categorise tenure in the marine environment however is much more difficult than on land. Within Australia's offshore limits, freehold title is said not to exist, however there is the ability to hold lease rights to areas of the ocean. According to Dalrymple *et al.* [2003], a lease transfers a set of rights to the leaser for a select period of time. Such rights include aspects of freehold including the right to bar access to the area under lease and the ability to borrow against the lease (e.g. aquaculture and fisheries).

Indigenous tenure also exists within the marine environment after the High Courts decision in the Croker Island Case, giving indigenous Australian's non-exclusive rights to areas of the ocean. Land administrators have struggled to incorporate this type of tenure into Australian's cadastral system, due to the existence of multiple stakeholders and users of the same parcel of land.

Within the marine environment, overlapping interests are common place. Within the terrestrial environment, this is less common. The terrestrial cadastral systems within Australia have been created primarily to facilitate the creation of a land market, driven by private transactions. Hence when managing forms of tenure other than freehold, the solution has been to try to convert those other forms of tenure into some form of freehold, in order to create the ability to transact that land. This has not always been effective, as seen in the inability to effectively incorporate native title into Australia's cadastral systems [Brazenor *et al.* 1999].

At the moment, freehold title and hence private transactions, generally do not exist within the marine environment. Basically the government regulates all transactions that occur. The major advantage of this is that the government defines the boundaries to manage access to and exploitation of various marine resources. The government also defines the rights, restrictions and responsibilities attached to such boundaries. It is up to the user to attain knowledge of these rights and abide by them, even if several sets of rights exist within the one area. The real need within the marine environment is for stakeholders to be able to have clear spatial and legal knowledge of such rights, and not necessarily the ability to transfer the rights (although this will most likely need to be looked at in the future).

Legal Principles

The legislative framework that governs land administration processes within Australia must uphold standards related to the resolution of land ownership, including boundary definition and transactions. For example in the Victorian case, these are well documented within legislation such as the Property Law Act 1958 (Vic), Transfer of Land Act 1958 (Vic) and the Subdivision Act 1988 (Vic). In general, legislation is used to describe how a boundary should be demarcated, not the precise location of the boundary (it must be noted that this is not always the case, with boundary descriptions such as the location of national parks embedded within legislation). The 'point of truth' for boundaries is within survey plans. In the marine environment, this is generally the reverse, with the point of truth' for the definition of boundaries lying in statutory descriptions. Conventional survey plans are still used, but are typically confined to the administration of ports and harbours as well as leasehold land below high water mark (elements of freehold tenure) [Todd 2001]. It is therefore imperative that the boundaries defined within legislation are able to be clearly visualised. This is not always easily accomplished however.

Although monuments such as buoys and posts etc. are used in administering some areas of the marine environment (particularly close to shores and beaches), monuments are not utilized in the same way as in the terrestrial environment. Due to this inability to utilise monuments in the physical description of most boundaries within the marine environment, the need to have spatial and legal certainty of rights is fundamental to the creation of a working marine cadastre. Hence maritime boundaries embedded within legislation need to be geo-referenced. The amount of legislation describing spatial boundaries and rights however is large, making such a task difficult. Added to this difficulty is that boundaries may be described by reference to geographical positions, meridians, parallels, geodesics, place names and geographical features. The reference to such features must also be interpreted, creating further ambiguity. There is a need for standards in the way in which boundaries are described within legislation, as seen on land within legislation such as the Subdivision Act 1988 (Vic).

Institutional Principles

Institutional principles put in place the governmental structures for the operation of both terrestrial and marine management systems. The policy principles discussed above drive institutional change in a top down approach, through the use of institutional principles such as a centralised governing body, departmental structures as well as government-private sector relationships and partnerships.

Centralised Governing Body

Within the marine environment, the Commonwealth government has created the National Oceans Office (NOO) to coordinate the development of regional marine plans. These plans are based on ecological rather than state boundaries, with the South-East regional marine plan being the first to be developed (which includes marine areas of Tasmania, Victoria, New South Wales, South Australia and the Commonwealth). The plan concentrates on Commonwealth aspects of the South-East marine region. However it is recognised that the majority of maritime activity occurs within Australia's coastal zone, to which the NOO does not initiate policy or management strategies. This creates separate jurisdictional areas within Australia's marine environment.

Due to Australia being a federation of states, it may not be possible to develop a marine cadastre that is free of all complexities and idiosyncrasies, in much the same way as the development of Australia's terrestrial cadastral systems. They can be minimised however through the identification of lead agencies within each state, the Northern Territory and the Commonwealth. This will foster cooperation on the development and implementation of national policy and will drive the legislative and institutional reform needed to implement a national marine cadastre. The implementation of governing bodies in the fashion described above will enable good central direction and coordination in the development of a national marine cadastre. This centralisation is aligned to a certain extent with the development of Australia's terrestrial cadastrals.

Partnerships

The cadastre is part of the basic infrastructure of a country and should therefore be the responsibility of the government [Williamson 2001]. A key to the successful implementation of the cadastre is the establishment of partnerships within and between government agencies and industry. Within Victoria's terrestrial cadastral system for example, the development of such partnerships has seen various tasks contracted out to the private sector. The majority of all surveying and mapping is now undertaken by the private sector, with government surveyors undertaking a quality assurance role through the inspection of plans of survey. The collection of other forms of data, and the maintenance and updating of that data, have also been contracted out to the private sector. This demonstrates the need for strong partnerships between the public and private sectors.

Within the marine environment, the development of 'task-specific' management techniques has been fuelled by a lack of partnerships between the private sector and government. Various industry stakeholders collect and disseminate spatial data for their own use, creating 'data silos' making data integration and access difficult. Creating partnerships and linking stakeholders is the key to facilitating access to such data. An example of such a partnership can be seen within Victoria's terrestrial environment, with the Victorian Government initiating the Property Information Project (PIP) to aid in the collection and maintenance of the State's property information. The project implemented a partnership between the state government and Victoria's 78 local governments. The State government through Land Victoria provided some money and assistance to local councils to aid them in matching their rates database with the cadastral map base, creating a property layer. Each local government is provided with the fully maintained and updated cadastral/property base at no cost. This is in return for local governments adopting Vicmap as their property base, allowing key property information to be fed into the map base, and to advise Land Victoria of all proposed plans of subdivision and changes to property information [Jacoby *et al.* 2002]. This project has been a huge success with Vicmap able to populate its cadastral dataset and deliver a key component of SDI for Victoria [Jacoby *et al.* 2002].

The creation of lead agencies within each jurisdiction would also facilitate dialogue on management aspects that straddle jurisdictional borders. This is also true in developing partnerships with terrestrial cadastral agencies, as it would increase the ability to link spatial information at the land-sea interface, enabling more efficient and sustainable development of the coastal zone.

Technical Principles

The use of institutional principles to guide the development of a marine administration system is also dependent on technical principles needed to actually implement such a system. Once again there are distinct similarities and differences in the terrestrial technical principles that could be utilised in the marine environment.

Boundary Delimitation

Boundaries mark the limit of each tract of real estate. In legal terms, a boundary is a line that divides two adjoining estates, while in common language the term denotes the physical objects by reference to which this line of division is described, for example cadastral pegs [Dale and McLaughlin 1999]. In the terrestrial environment boundaries are usually physically demarcated by a fence or hedge, neatly defining the area to which a set of rights, restrictions and responsibilities is attached. In Australia, such boundaries are 'fixed' with the precise line being accurately determined. There are however around 10% of boundaries within the terrestrial environment which are 'general' (graphical), where the precise line on the ground has not been determined. They are based on natural or artificial features, such as high water mark, or walls and buildings as found in strata subdivisions.

Such general boundaries are found within the marine environment as physical demarcation is generally not possible. As discussed earlier, the point of truth for the definition of maritime boundaries is the legal description, and to a lesser extent, conventional survey plans and physical demarcation. This means that boundaries are delimited, not demarcated, giving rise to a measure of uncertainty, given a lack of knowledge of the accuracy of a position. This is due to the process in which maritime boundaries are delimited, the realising of maritime boundaries, and ambiguity in the visualisation and realisation of the coastline and adjoining interests [Fraser *et al.* 2003]. The ability to have clear spatial and legal certainty in regard to maritime boundaries depends on access to knowledge about the integrity of maritime boundary locations. Detailed research into marine boundary uncertainty is being undertaken within the broader context of the ARC marine cadastre project, but not specifically within this paper.

Spatial Data Maintenance

The need to reduce duplication and a greater emphasis on the management of land resources through continual maintenance of information have been the major driving force in the development of state-wide Digital Cadastral Databases (DCDB) in Australia over the past 20 years [Williamson, 1996]. A DCDB shows a computerised map of cadastral boundaries within a jurisdiction such as Victoria. All cadastral surveys carried out within Victoria are incorporated into the DCDB for the state, enabling a map of all land parcels within the entire jurisdiction to be developed and maintained.

The task specific management techniques utilised in the marine environment create difficulties in developing such a database for Australia's oceans. The delimitation and subsequent creation of spatial datasets relating to maritime boundaries is undertaken by a variety of agencies to various levels of accuracy and scale. Such data is stored in 'silos', from which integration is difficult. Boundaries in the marine environment also overlap. The ability to up-date and create a map of all boundaries within the marine environment could only be realised through the creation of interoperable datasets that can be accessed by all users. The need to update spatial information within the marine environment however is highly important, as it enables users and stakeholders to have the necessary tools for effective management.

Terrestrial and Marine Management

The primary aim of current land based cadastral systems within Australia is to facilitate an active land market, whilst also evolving to support a broad range of land administration and land management functions, such as crown land management, natural resource management and facilitating emergency management and counter terrorism. Within the marine environment, the need for private transactions is currently limited, due to the lack of freehold rights, although the ability to meet the business needs of users is a strong driving force in creating a transaction based system in the marine environment. Currently, the major need is to have clear legal and spatial certainty of spatial boundaries and associated rights, restrictions and responsibilities that occur within the ocean, focusing on resource management. Table 1 outlines the comparative analysis of the terrestrial and marine environments in terms of cadastral principles.

The table shows that while there are significant difficulties in applying some of the technical principles to the marine environment, broader policy is applicable. There are however issues of interoperability and access to spatial data that cadastral principles fail to adequately address. In order to address such issues, the concept of a Spatial Data Infrastructure has also been explored within research on the ARC projects.

| PRINCIPLES | TERRESTRIAL CADASTRE | MARINE CADASTRE |
|---|---|--|
| Policy Principles | | |
| <i>National Policy</i> | No | Australia's Oceans Policy |
| <i>Aim of cadastre</i> | Creation of active land market - ability to trade rights in land. | Spatial boundary management system - ability to trade rights not as big an issue. |
| <i>Dynamic</i> | Yes | Yes |
| Tenure Principles | | |
| <i>Freehold tenure</i> | All aspects | Some aspects - there is the ability to hold lease rights |
| <i>Native Title</i> | Exclusive and non-exclusive | Non-exclusive only. |
| <i>State administered</i> | Yes - minority of land | Yes - majority of marine environment |
| Legal Principles | | |
| <i>Legislation</i> | Used to describe how boundaries should be demarcated. | Used to describe precise locations of boundaries. |
| <i>Point of truth for boundaries</i> | Monuments - primary. Coordinates - secondary. | Statutory regulations - primary. Conventional survey plans - secondary. |
| Institutional Principles | | |
| <i>National Governing Body</i> | Not traditionally - PSMA is closest. | NOO - Commonwealth governing body. |
| <i>State Governing Body</i> | Yes. | Each state needs to identify a lead agency in the marine environment. |
| <i>Centralised/Decentralised</i> | Centralised system within each state. | Centralised system within each state linked to an overarching Commonwealth system. |
| Technical Principles | | |
| <i>Boundaries</i> | Demarcated. | Delimited. |
| <i>Physically demarcated</i> | Yes. | No. |
| <i>Uncertainty</i> | No. | Yes. |
| <i>Dimensions</i> | 2D - there are instances where 3D is needed (e.g. strata title) but the solution has been to establish 2D on top of 2D. | 3D (aquaculture leases requiring depth) and 4D (introduction of time) boundaries needed in the marine environment. |
| <i>Overlapping boundaries</i> | Rarely | Common |
| <i>Systematic/Sporadic Implementation</i> | Sporadic. | Systematic. |

Table 1 - Terrestrial and Marine comparison in relation to the implementation of fundamental cadastral principles [Binns 2004]

SPATIAL DATA INFRASTRUCTURE

An SDI aims to facilitate the discovery, sharing and transfer of spatial data between different spatial data users. Just as the idea of extending the land cadastre out in to the marine environment is being explored, so to is the concept of SDI, which has until now mainly dealt with land related spatial data. Around the world people involved in marine management, governance and planning are recognising the value of spatial information to aid in their decision-making [Doody 2003, Forse and Collier 2003]. In response, many countries including Ireland [O'Dea *et al.* 2004], Canada [DFO 2001], the USA [Fowler and Treml 2001] and Australia [Finney and Mosbauer 2003] are developing different tools and mechanisms that improve the availability of marine and coastal spatial data.

The Australian Spatial Data Infrastructure (ASDI) is a tool that coordinates sharing of spatial data between people. In 2002 ANZLIC, Australia's peak spatial information council extended the definition of the ASDI to also include the marine environment. However there is little progress in any of these initiatives in implementing a true marine or coastal SDI.

The overall concept of the ASDI applies to the marine environment, however the nature and components need to be tested for their applicability to marine and coastal spatial data. The ASDI definition describes SDI as being 'the people, policies and technologies that enable the sharing of Australia's spatial data'. The next section examines how this definition applies to the marine environment, compared to the terrestrial environment.

People

This component is one of the most important components of SDI. The people in SDI are the data providers, value-adders and data users. In the marine environment these people will come from private industries such as shipping, fishing, aquaculture and conservation, as well as from government at local, state and national levels. There will already be some degree of spatial data management that is occurring within these groups, even if only within or between organisations. It is important that this is recognised and can be built upon for the SDI to be

relevant to those who will use it. This data management will also need to be integrated with the standards and policies that are set at global, regional and national levels.

Both Binns *et al.* [2004] and ANZLIC [2003] have reported that a barrier to SDI development and marine SDI development is 'immature institutional arrangements' and the reluctance of many organisations to share their data. Therefore a challenge in developing a marine SDI will be in encouraging cooperation and a culture for spatial data sharing between the institutions involved in marine and coastal spatial data collection and use [Rajabifard and Williamson 2003]. This means encouraging data producers to become the custodians of certain marine datasets, and producing these datasets according to specified standards and policies, and making them available through defined access-networks. In this way the custodians of marine spatial data will play a fundamental role in shaping and implementing both a marine SDI and a marine cadastre, as each custodian has to be responsible for a data layer within the SDI or a layer of information that is part of the cadastre. These custodians must not only follow set standards and policies, but must cooperate with each other in defining these standards and policies. Underlying these issues is the need for an institutional framework that will support marine SDI development, and impose responsibility for organising and building the SDI.

Policies

Policies are influenced by international best practice in spatial data management and exchange. Marine data management policies are developing in Australia and the USA. In the United States NOAA Coastal Service Centre has developed a policy for Coastal NSDI that aims to link the coastal management community with the National SDI. Australia's Marine Science and Technology plan sets out policy for marine spatial data sharing and management. The policy includes: avoiding duplication, data consistency, improved access to data and coordinated data management [NOO 1999].

The current ASDI policies cover access, data custodianship, conformity, quality, content, industry engagement, avoidance of duplication and sensitivity [ANZLIC 1999]. In applying these policies for terrestrial spatial data to the marine and coastal environments it is likely there will be differences in terms of data quality, data access and privacy. Data quality depends on collection, completeness, currency, reliability etc. and due to the complexity of the marine environment and the different technologies used for data collection, may be more difficult to achieve at the same level as terrestrial data. Fixed line data transfer supports data access onshore. In the marine environment there may need to be the capability for wireless data transfer, for people accessing or uploading data offshore. This could provide critical information in disaster response and emergency planning, for example the need for real-time water temperatures and currents in a search and rescue operation. Privacy over spatial data in the marine environment is a concern with many countries reluctant to share spatial information relating to their marine jurisdictions, and as such there may need to be different privacy policies for offshore data [Bartlett *et al.* 2004].

Technologies

Spatial technologies such as GIS, remote sensing, and GIS are becoming increasingly recognised as decision support tool in the marine and coastal environments [Bartlett *et al.* 2004]. The ability to be able to visualise, integrate, map and analyse spatial data is important in planning, and decision-making. Marine SDI would support these technologies by providing access to data. In order for people to be able to use many different data sets from a range of custodians that relates to both marine and terrestrial data, there needs to be standards that enable interoperability of the data sets contained in the SDI. Standards for SDI specify regulations for data access, content and exchange [ANZLIC 2002]. While the same standards may be able to be used for marine spatial data as are used for terrestrial data, there is limited actual application of these standards by many data producers in the marine environment [CSIRO 2004].

Access networks are usually on line web portals, data warehouses or one-stop data shops. These allow users to search for metadata and data and either download it or provide information for the data custodian. Data access networks are being set up to provide access to marine and coastal information around the world. However often these are occurring separately to the countries SDI and to access networks for terrestrial data. An exception is the Australian National Oceans Office (NOO) proposed Oceans Portal, which aims to be 'one of the first practical demonstrations of the ASDI put into action' [Finney and Mosbauer 2003]. The Oceans Portal plans to use standards and policies from the ASDI, but hasn't yet tested the appropriateness of these to the marine environment.

XML is a data exchange format that is used to share data through the Internet. Marine XML is developing to allow interoperable marine data exchange. There are several projects around the world examining the creation of a marine specific XML. The International Oceans Commission (IOC) has established a Marine XML consortium, which is looking at developing an international standard form of marineXML. Standardisation at an international level is required for interoperability on a global and regional level, and otherwise marineXML will become 'just another data format' [Ronai *et al.* 2002]. The main benefit of using an XML is that it provides a common format to store data, and so allows data exchanged easily between providers, value adders, and users. Marine XML is being developed and used by the Australian Oceanographic Data Centre to encode their marine data for storage and exchange [Ronai *et al.* 2002].

Spatial Data Access - Oceans Portals

Internet portals/ clearinghouses/ warehouses are developing around the World that intend to be a source of marine and/or coastal spatial data and information. For example there are several in Australia: the Oceans Portal proposed by the Australian National Oceans Office (NOO), Geoscience Australia's Australian Marine Boundaries Information Systems (AMBIS), and CSIRO's marine data directory – Marlin. In Ireland the Marine Irish Digital Atlas aims to be a 'single source for marine and coastal geospatial information in Ireland' [Dwyer *et al.* 2003]. There are other examples at National and State levels in the USA, France and many other countries. Global level oceans portals are developing too, such as the Oceans Biogeographic Information System (OBIS) – a virtual repository of oceanographic and biogeographic information.

These initiatives are all examples of possible *access-networks* in an SDI, delivering front-end access to data through an Internet portal. There are many different examples of these, most developed to support decision-making for a particular discipline or location through better access to spatial data. These would make-up one part of the SDI, with the rest being the back-end infrastructure such as the standards, policies and technologies. The main difference between these and an SDI is that most of these portals only focus on providing data and information. However the data will only be useful if it is compatible with the potential users system. Therefore the clearinghouse or access network needs to be linked with the other SDI components (people, data, standards and policy) so that data is accessible and also usable [Crompvoets *et al.* 2004]. Some portals have recognised this, for example the Australian Oceans Portal suggests using Open GIS Consortium (OGC) standards and technology to comply with international and national standards as recommended by ANZLIC for the ASDI [Finney and Mosbauer 2003]. This would make the spatial data interoperable allowing many different people to use the same data. This is based on existing research into SDI that, until recently, has mainly been applied to land-related spatial data (as discussed above). Research is now needed to see if these ideas are as applicable to sharing marine and coastal spatial data. Existing oceans portals can take advantage of this research to enable them to provide more interoperable and useful spatial data by using the SDI as an enabling platform.

DISCUSSION

A marine cadastre relies on having several different spatial datasets, for example boundaries, legislation, leases and licenses etc., available and accessible to potential users. It also relies on this information being interoperable and integratable. A marine SDI will enable these needs to be satisfied by specifying standards, technologies and policies to which the datasets must conform. In this way, as was recommended by the Permanent Committee for GIS in the Asia-Pacific (PCGIAP), a marine cadastre forms an important data layer within a marine SDI.

The implementation of the ASDI is enabling such access to data in the terrestrial environment and if utilised in the marine environment, would provide the platform for data access within the development of a marine cadastre. Figure 1 outlines the basic, generic concept for a marine SDI, as being researched within the ARC marine cadastre project. This concept is based upon Open Standards and access through a distributed network of data custodians. This will facilitate the design of a system that is compatible with the terrestrial environment (ASDI development), taking advantage of current research so as not to 're-invent the wheel'.

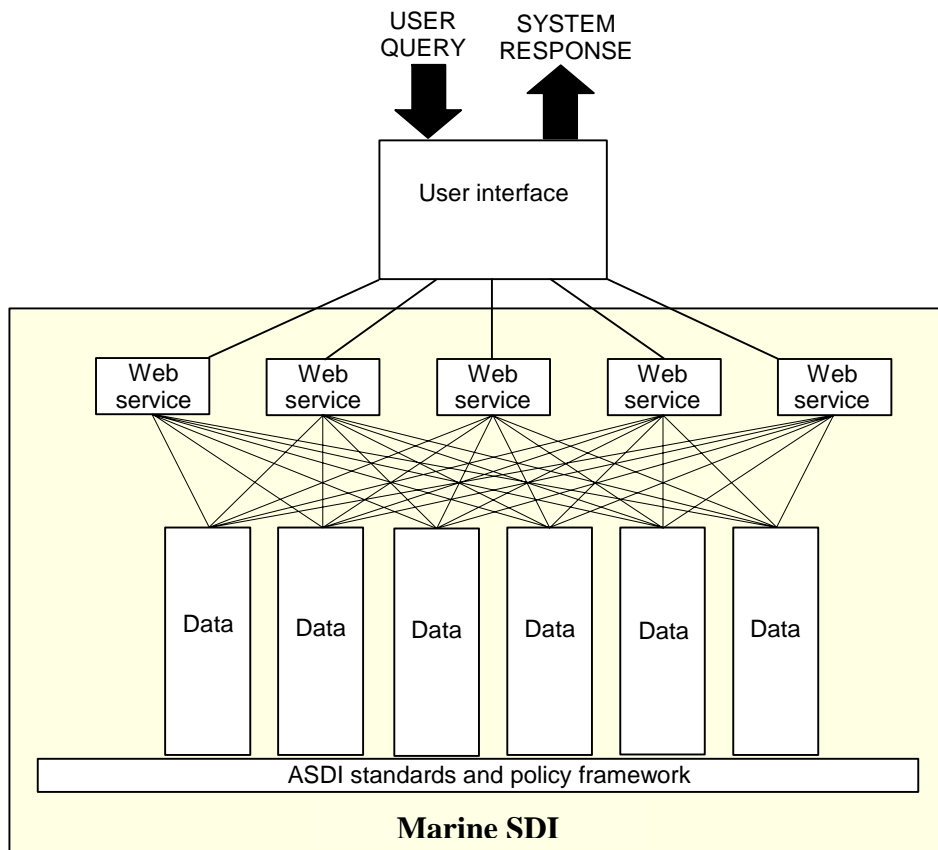

Figure 1 - Marine SDI (incorporating Marine Cadastre) (Based on work undertaken by the Marine Cadastre Research Group at the Department of Geomatics, the University of Melbourne).

User Interface

The marine SDI will be designed to be the major access point to spatial information and tools in relation to legally defined boundaries within the marine environment. The creation of a marine SDI would help to ensure that the authoritative and well maintained data is being utilised and accessed to manage the marine environment. In order to achieve this, a user interface must be developed which would enable users to access and query spatial data. Access to spatial data in the terrestrial environment is to be conducted over the internet, and hence the marine user interface would be a web-site or HTML page. The design of such a site would not need to be undertaken until the last phase in the development of a marine SDI, as it is simply an interface tool linking users to data. An example of a query that could be posed by a user is:

based on my current location, what legislative restrictions impact on what I can do?

Web Services

The ability of the marine cadastre to meet the requirements of users lies in the quality and versatility of web services that it would support. These services would be located within a maintenance environment and could include:

- the ability for users to search for information about data and to access the data itself;
 - o a metadata search facility with links to relevant metadata
 - o keyword search facility
 - o spatial location search facility with the ability to view location on a map
 - o data download mechanism to access spatial data
- interrogation services
- optional services specific to providers and value added services including license agreements, payment options for downloading various data and web services, and user controls.

Current research within the Spatial Interoperability Demonstrator Project is showing how services such as those mentioned above can be utilised in the terrestrial environment through the use of open and interoperable standards.

Data

The data within the marine SDI could include many datasets fundamental to administering the marine environment, for example bathymetry, water temperature and salinity, tide and current information, and natural resources. It would also include all marine spatial data pertaining to legally defined boundaries, as well as that which supports the development of web services, such as state and federal legislation and international treaties. Data which would give the marine cadastre a multi-purpose function may also be included; this may include information such as recreation zoning, speed limits and navigational information. Such datasets would be maintained and housed by various custodians as discussed above. In order to create interoperability between datasets, it would be logical to expose data to users via a homogenized data form developed through the implementation of international best practice.

CONCLUSIONS

As discussed within this paper, there are currently a large number of agencies, stakeholders and users involved in the management of Australia's marine environment. Each operate within a set of legally defined boundaries and are responsible for the collection, collation and updating of spatial data relating to these boundaries. However, there are currently no standards in the marine environment for the collection of such spatial data, and hence the majority of data is stored within 'data silos', with little integration between each silo. The development of a marine cadastre aims to break down the barriers between these silos, enabling all users in the marine environment access to a variety of data, irrespective of the custodian or location of datasets.

The need to effectively manage the coastal zone as well as the need for integration of data between the three environments (land, coast, marine) requires a management system that incorporates them all. Currently many countries have a land administration system and some kind of marine administration system, but these operate as separate entities causing confusion and a lack of management at the coastal zone (Figure 2).

A more integrated approach would be supported by the development of a seamless SDI. This would allow people involved in administering the areas access to interoperable data from all environments and thus strengthen the chance of more integrated management. If two separate SDIs were created (land and marine) it would deepen the gap between these two administration systems and make coastal zone management more difficult. There is an opportunity for more research to be conducted into combining these initiatives and developing a seamless SDI that can include spatial data from all environments. It must be remembered that it has taken 200 years for Australia to establish its current land administration infrastructure. The key to success in the marine environment is to start simple, develop a strong marine cadastre framework foundation, and allow the system to evolve and grow as future uses arise. Using common SDI standards, policies and access networks can ensure that this spatial data is interoperable, facilitating the design of a seamless SDI and thus improving decision-making and administration in the coastal and marine environments.

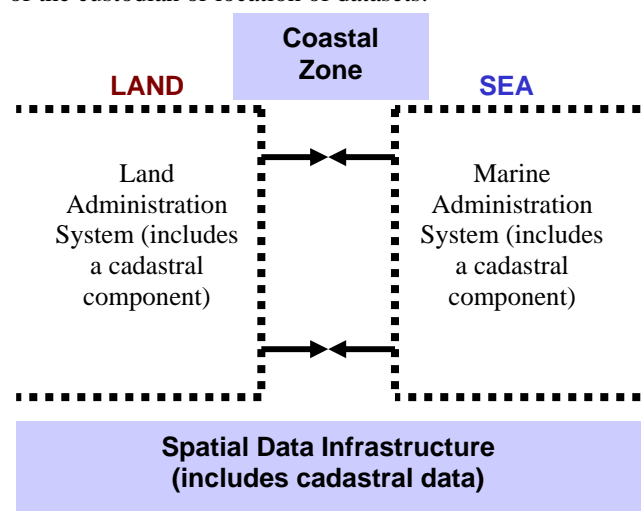

Figure 2 - Administration Systems [UN-PCGIAP 2004]

ACKNOWLEDGEMENTS

The authors wish to greatly acknowledge the support of the University of Melbourne, Land Victoria, Geoscience Australia, Department of Natural Resources and Mines Queensland, Department of Lands NSW, the Australian Research Council (ARC) and members of the Marine Cadastre Research Group and Centre for SDIs and Land Administration at the Department of Geomatics, University of Melbourne in the preparation of this paper and associated research. The views expressed in this paper are those of the authors and do not necessarily reflect the views of these groups.

REFERENCES

- ANZLIC (1999), **Policy Statement on Spatial Data Management** <http://www.anzlic.org.au/publications.html>
Website accessed on 06/06/04
- ANZLIC (2002), **Geographic Information Standards** <http://www.anzlic.org.au/publications.html> Website
accessed on 29/06/04
- ANZLIC (2003), **Implementing the Australian Spatial Data Infrastructure** ANZLIC Spatial Data
Infrastructure Standing Committee <http://www.anzlic.org.au/publications.html> Website accessed on
29/06/04
- Bartlett, D., Longhorn R., and Garriga M.C. (2004), Marine and Coastal Data Infrastructures: a missing piece in
the SDI puzzle. **7th Global Spatial Data Infrastructure conference**, Bangalore, India.
- Binns, A. (2004), Defining a Marine Cadastre: Legal and Institutional Aspects, **Masters by Research Thesis**,
Department of Geomatics, The University of Melbourne.
- Binns, A., Rajabifard, A., Collier, P. and Williamson, I.P. (2004), Developing the Concept of a Marine
Cadastre: An Australian Case Study, **The Trans-Tasman Surveyor**, vol 6, August
- Brazenor, C., Ogleby, C. and Williamson, I.P. (1999), The Spatial Dimension of Aboriginal Land Tenure, **6th
South East Asian Surveyors Congress**, 1-6 November, Fremantle, Australia.
- Crompvoets, J., Bregt, A., Rajabifard, A., Williamson, I.P. (2004), Assessing the Worldwide Developments of
National Spatial Data Clearinghouses. **Geographical Information Science** 18 (7) pp: 665-689
- CSIRO (2004), 'National Marine Data Policy', CSIRO Marine Data Centre. Available at
www.marine.csiro.au/datacentre/forums/nat_policy.htm, Website accessed on 27/07/04
- Dale, P.F. and McLaughlin, J.D. (1999), **Land Administration**. Oxford University Press, Oxford, UK.
- Dalrymple, K., Williamson, I.P. and Wallace, J. (2003) Cadastral Systems within Australia. **The Australian
Surveyor** 48 (1) pp. 37-49.
- Doody, J.P. (2003), Information Required for Integrated Coastal Zone Management: Conclusions from the
European Demonstration Programme, **Coastal Management** 30 (2): 163-173
- Dwyer, N., O'Dea, L., and Cummins, V. (2003), The Marine Irish Digital Atlas: A Web Portal to Coastal and
Marine Data in Ireland, **CoastGIS'03 Conference** Geneva, Italy
- Finney, K. and Mosbauer, A. (2003), **An Oceans Portal Accessing Distributed Bioregionalisation Related
Datasets Through a National Marine Registry**, National Oceans Office
<http://www.oceans.gov.au/pdf/PortalRequirements.pdf> Website accessed on 13/07/04
- Forse, J.E. and Collier, P.A. (2003), Assessing the need for an Australian Marine Cadastre, **Coastal GIS
Conference** Woolongong, Australia.
- Fowler, C. and Treml, E. (2001), Building a Marine Cadastral Information System for the United States – a Case
Study, **International Journal on Computers, Environment & Urban Systems Special Issues:
Cadastral Systems** 25 (4-5) pp. 493-507.
- Fraser, R., Todd, P. and Collier, P. (2003), Issues in the Development of a Marine Cadastre, **Addressing
Difficult Issues in UNCLOS: 2003 ABLOS Conference** 28-30 October 2003, Monaco.
- Jacoby, S., Smith, J., Ting, L., and Williamson I.P., (2002), Developing a Common Spatial Data Infrastructure
between State and Local Government – An Australian Case Study, **International Journal of
Geographic Information Science**, Vol. 16, No. 4: pp. 305-322.
- NOO (1999), **Australia's Marine Science and Technology Plan**
http://www.oceans.gov.au/marine_science_tec_plan/mstplan.pdf Website accessed on 27/09/04
- Rajabifard, A. and Williamson, I.P. (2003), Anticipating the Cultural Aspects of Sharing for SDI Development,
Spatial Sciences Conference, Canberra, Australia.
- Ronai, B., Sliogeris, P., De Plater, M., Jankowska, K. (2002), Development and Use of Marine XML within the
Australian Oceanographic Data Centre to Encapsulate Marine Data, **Marine Data Exchange Systems
Conference**, Helsinki, Finland.
- Todd, P. (2001), Marine Cadastre – Opportunities and Implications for Queensland, **A Spatial Odyssey: 42nd
Australian Surveyors Congress**, 25-28 September 2001, Brisbane, Australia.
- UN-PCGIAP Working Group 3. (2004), **Report on the International Workshop on Administrating the
Marine Environment - The Spatial Dimension**, Kuala Lumpur, Malaysia, May 4-7
- Williamson, I.P. (1996), Establishing Coordinated Cadastres – Australian Experiences. **International
Conference on Cadastral Reform**, 16-17 July 1996, Korea.
- Williamson, I.P. (2001), Land Administration “best practice” providing the infrastructure for land policy
implementation, **Land Use Policy**, 18 pp.297-307.